

SLE Hot Printers

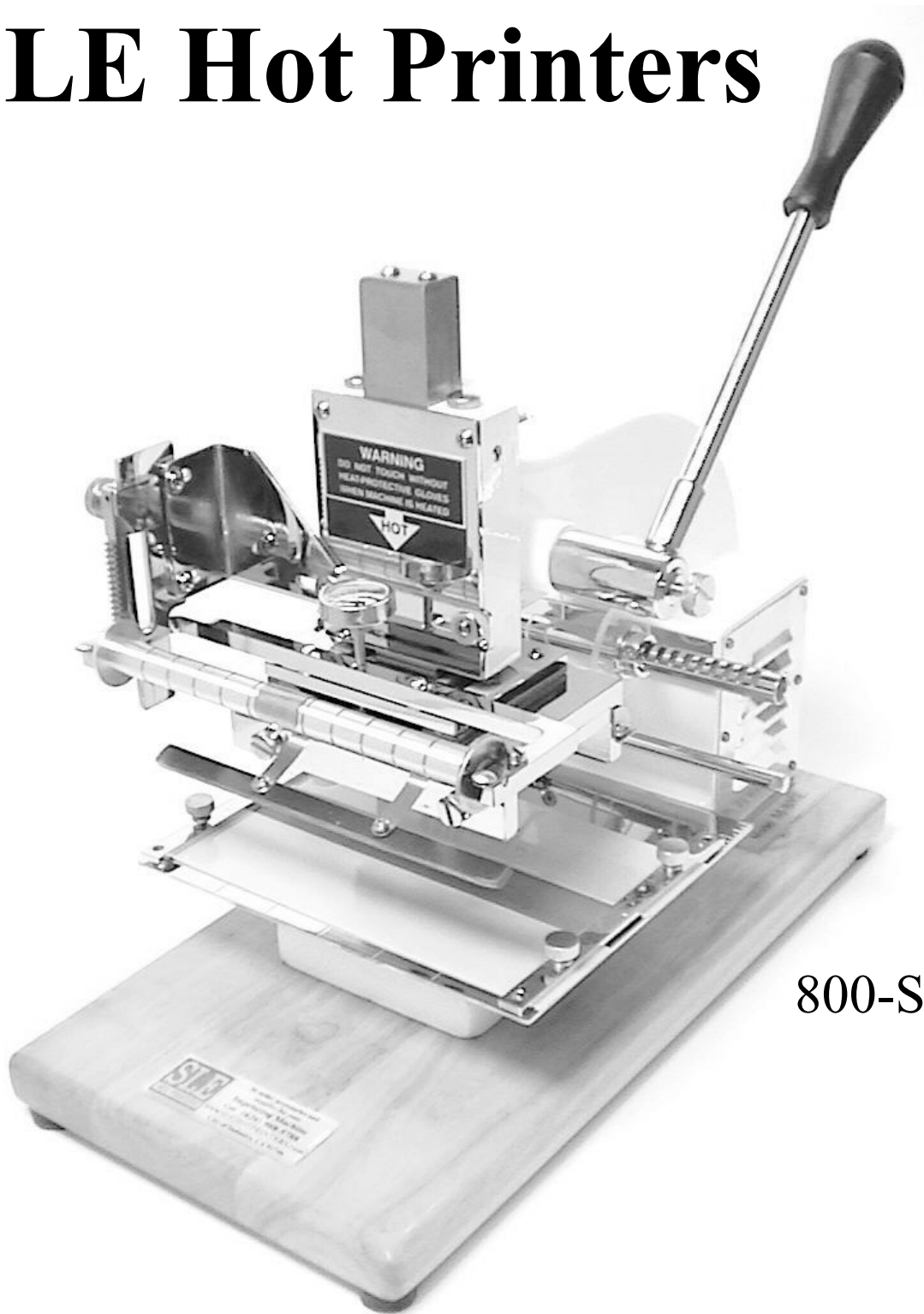

800-Series

Contents

Page

Introduction

Safety Notes

Getting To Know Your SLE Hot Printer

Preparing for Operation

- Setting up your hand-operated SLE Hot Printer
- Setting up your air-operated SLE Hot Printer
- Loading Foil
- Setting Foil Pull
- Unloading Used Foil
- Setting Temperature

Preparing the Type, Emblem or Die

- Printing with a 1-Line or 2-Line Type Holder
- Printing with the Open Chase Type Holder
- Printing with Engravings
- Doing Test Imprints

Common Problems & Solutions

Special Imprinting Applications

- How to imprint on ribbons
- How to imprint on napkins
- How to imprint on matchbook covers
- How to imprint on pencils
- How to imprint on stationery, invitations or announcements
- How to imprint on Emboss-a-plates
- How to imprint on larger items
- How to imprint on Mylar balloons
- How to imprint on leather articles
- How to imprint on favor tags and confetti cards
- How to get foil imprinting effects for computer output
- How to imprint on glasses, ceramics and metal objects using Crysteramics

Supplies

- Foils
- Type Set, Spacers, Emblems and Dies
- Imprintables

Caring for Your Hot Printer

How to Promote Sales

List of Optional Accessories

Specifications

Introduction

Congratulation on acquiring your new 800-series SLE Hot Printer and welcome to the exciting, lucrative world of foil imprinting.

The SLE Hot Printer is a versatile machine, having a range of capabilities equal to that of many commercial foil presses. With its precision engineering, ease of operation and reliability, your SLE Hot Printer will perform faithfully and profitably for you year after year.

Your SLE Hot Printer is designed for simplicity and ease of operation. Anyone should be able to achieve excellent results in a very short time. To get full use of all the features of your SLE Hot Printer, we urge that you carefully study and thoroughly understand the instructions contained in this manual and the accompanying video, until you can execute each of the prescribed procedures with reasonable skill and confidence. Proficiency will come with time and continued practice. For quick reference during operation, keep this manual in a handy location.

The machine models pictured in this manual are the 6-inch M-800E and AM-800E. However, the information covered is equally applicable to the following models:

MODEL M-800B	3.5-Inch Hand-Operated Machine
MODEL AM-800B	3.5-Inch Air-Operated Machine
MODEL M-800A	5-Inch Hand-Operated Machine
MODEL AM-800A	5-Inch Air-Operated Machine
MODEL M-800D	6-Inch Hand-Operated Machine
MODEL AM-800D	6-Inch Air-Operated Machine

What is "Foil Imprinting"?

Foil imprinting or "Hot Stamping" is a process of permanently imbedding text or images onto a surface like paper, plastic or leather with a very thin layer of foil. The foil usually comes in gold, but is also available in many colors and textures.

The vibrant color and depth of foil imprinting imparts a 3-dimensional effect not obtainable with conventional printing with ink. The process begins by setting the desired message on special metal type or photoengraved dies. The type are inserted into the machine and heated to the operating temperature. The article to be imprinted is then placed on the printing table under the foil. When the machine handle is pulled, the type or dies will melt a coloring agent into the article leaving a crisp, permanent mark.

With your SLE Hot Printer you can personalize thousands of articles such as award ribbons, napkins, greeting cards, pencils, book covers, matchbooks, playing cards, letterheads, business cards, leather goods, photographs, slide mounts, Mylar balloons, plastic name badges, satin pillows, champagne glasses, ceramic mugs and candles.

Safety Notes

Your SLE Hot Printer and accessories have been designed to assure years of profitable, trouble-free service, provided it is carefully maintained, handled with care and properly used. As with all mechanical and electrical devices, it is essential that certain safety precautions be fully understood and followed, to prevent injury to the operator and/or damage to the machine. In the interest of safety, you are urged to read the following precautionary suggestions carefully before operating the machine.

- Place the machine on a stable counter or table, to prevent undue movement during operation.
- Keep the work area clean and clutter free.
- Do not operate this machine near water, wet locations, or outdoors.
- This machine should be operated from the type of power source indicated on the marking label. If you are not sure of the type of power available, consult your local power company.
- Do not allow anything to rest on the power cord. Do not locate the machine where a person will step on the cord. Inspect power cord regularly and replace any worn or damaged cord.
- Use of an extension cord with this machine is not recommended or authorized. Users should check building codes and insurance requirements if an extension cord is to be used. Ensure that the total ampere ratings of the products plugged into the extension cord do not exceed the extension cord rating.
- Make sure that the total amperage of all products plugged into the wall outlet does not exceed the outlet rating, and that outlet is properly fused according to its electrical ratings.
- Toxic/inflammable material should not be placed near the machine. Do not attempt to imprint on any object or product containing toxic/inflammable material.
- Dress appropriately for the job. Do not wear any jewelry or loose clothing, which could become entangled in the machine.
- Avoid contacting the heated Type Holder/Heater Platen with bare hand as this may cause severe burns. These portions of the machine can become very hot during operation.
- Never place your hands on the printing table during operation of the machine.
- When changing type sets or engravings, always use some form of protective gloves or the supplied Holding Pad.
- Keep this machine and all supplies out of reach of children.
- Turn off machine when not in use. Unplug machine from the wall outlet before cleaning and servicing.
- For air-operated units, never use the cycle mode for any application other than ribbon imprinting. Always turn off the cycle mode when not in use.
- When setting up or changing foil on air-operated units, always turn off power to the Pneumatic Control Box.
- Never leave machine handle on the machine when the Pneumatic Control Box is in use. When air-operated units are to be used as hand operated units, always unplug the power to the Pneumatic Control Box and disconnect the air hose to the compressor.

- Bleed off air pressure in the system when not in use and before servicing or storage. To release the pressure, turn and press the valve underneath the Air Filter/Regulator.
- Disconnect electrical power to machine and compressor when not in use. Unplug machine from the wall outlet before cleaning and servicing.

Getting to Know Your SLE Hot Printer

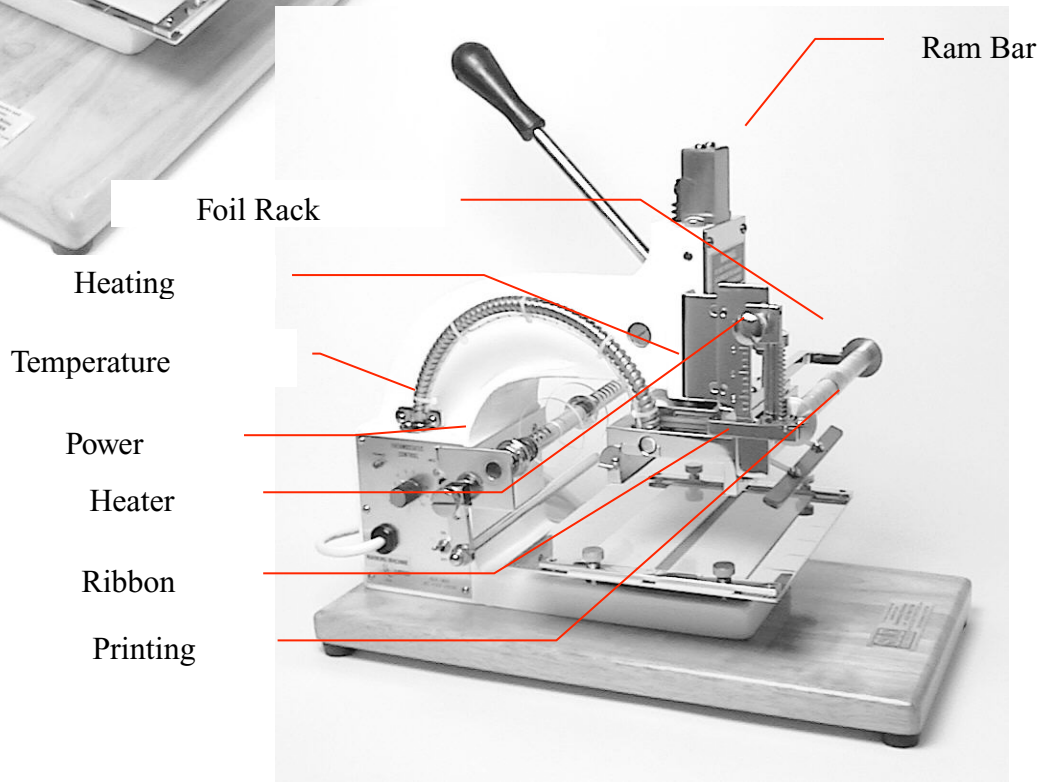
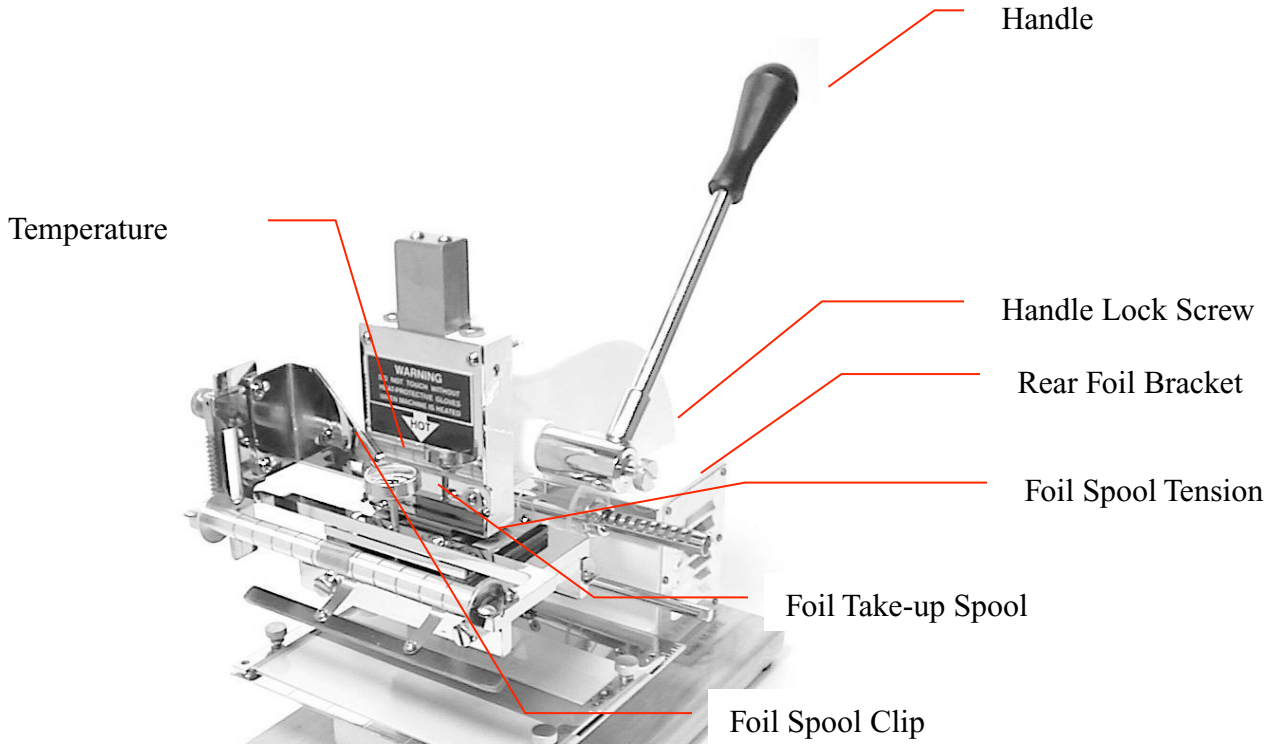

Model AM-800E

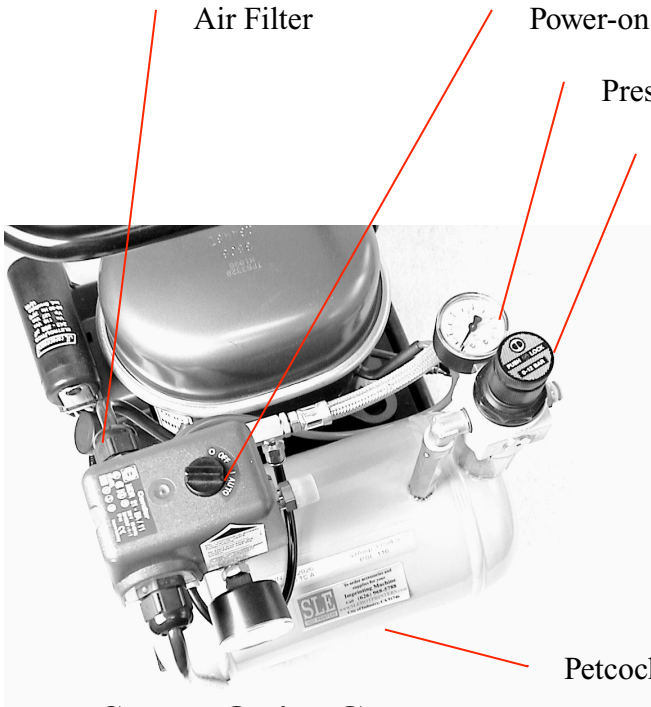

Super-Quiet Compressor

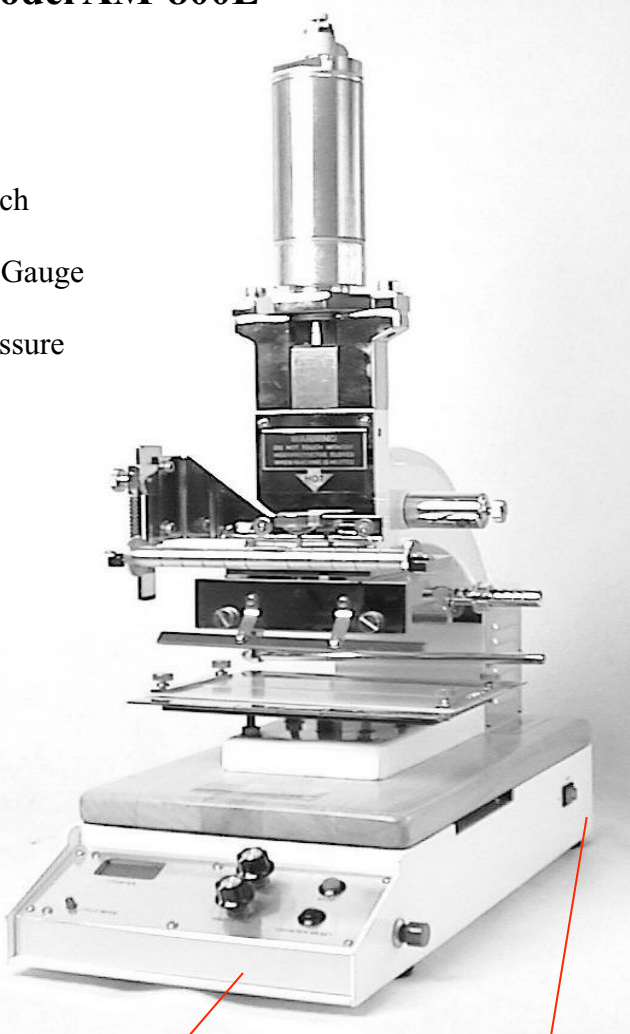

Pneumatic Control

Power-on

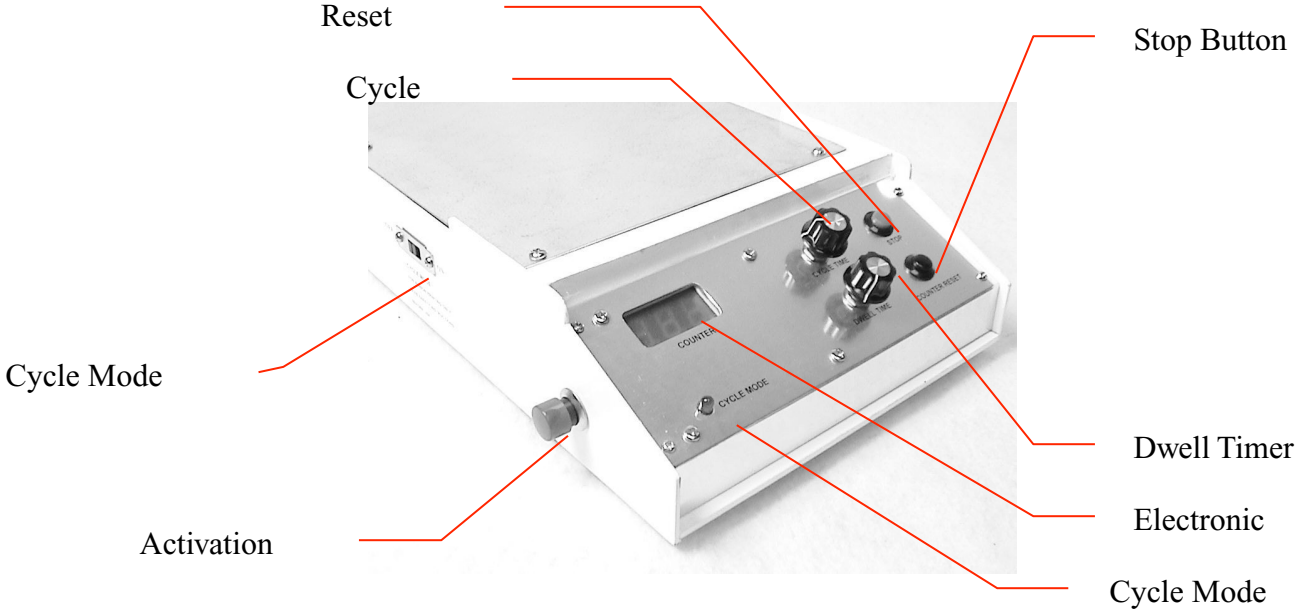

Reset

Cycle

Cycle Mode

Activation

Stop Button

Dwell Timer

Electronic

Cycle Mode

Attachments and Accessories

Depending on the particular machine package you purchased, you might have one or more of the following accessories.

Multipurpose Gauge Bar - serves as a vice to hold Napkin Guides, Matchbook Guides and other accessories firmly in place when imprinting.

Type Holders - hold the text, logos, or artwork you wish to transfer onto the item you are imprinting. There are several different styles of Type Holders, which are described below:

- 1-Line Type Holder holds one line of 18-point body type.
- 2Line Type Holder holds two lines of 18-point body type.
- 3Line Type Holder holds three lines of 12 or 18-point body type.
- 24/36-point Type Holder holds one line of 24 or 36-point body type.
- 7-Line Type Holder holds seven lines of 18-point body type.
- Open Chase Type Holder - consists of a set of Lead Rule, Quoins, Allen Key and a Typesetting Stand. Used for multi-line imprinting of various type sizes.
- 72-point Type Holder holds one line of 72-point type.
- Wafer Die Holder available for 108 and 160-point dies.
- Wafer Holder for Open Chase - holds dies up to 1.5 x 2.0 inch. Used in combination with the Open Chase Type Holder.

Adapter Sleeves - fit into the Heater Platen of your SLE Hot Printer to keep Type Holders in place. To install an Adapter Sleeve, slide into the Heater Platen from either side and lock into place by flipping the Butterfly Clips on both sides. To remove an Adapter Sleeve, use the eraser end of a pencil and push the sleeve out. Be sure to use the Holding Pad, as the Adapter Sleeve can become very hot.

- The 1-Line Adapter Sleeve is for 1-Line 18-point Type Holders.
- The Multi-line Adapter Sleeve is for 2-Line 18-point Type Holders, 3-Line 12-point Type Holders and 1-Line 24/36-point Type Holders.
- Some Adapter Sleeves have a Die Holder built in to allow quick setup of dies and letters. This is particularly useful for printing items like matchbooks or favor boxes.
- Open Chase Type Holders, 72-point Type Holders, Wafer Die Holders and 3-Line 18-point Type Holders fit directly into the Heater Platen.

Kopyfoil Attachment - used to convert black ink from computer or copier output into brilliant foil colors.

Napkin Guide - for diagonal imprinting of napkins. The Gauge Bar is used to secure the Napkin Guide to the Printing Table.

Matchbook Guide - used to imprint the outside cover of matchbooks.

Pencil Guide - holds hex pencils in place to insure perfect imprinting.

Ribbon Guide - used to hold the ribbon in place to ensure a straight and uniform imprint. Depending on your specific model, the Ribbon Guide is either built into the Printing Table or attaches to the Printing Table similar to the Gauge Bar.

Ribbon Spindle - for holding spools of ribbon to be imprinted.

Extended Printing Table - allows you to imprint larger items like satin pillows, scrapbooks and wedding albums quickly and easily. In addition, it helps speed up imprinting of greeting cards and stationery.

Billfold Clamp - used to hold small leather items in place for imprinting.

Book Clamp - used to hold bibles, photo albums or scrapbook covers in place for imprinting.

Holding Pad - serves to protect you from the heat when handling hot items such as Type Holders and Adapter Sleeves.

Type Box – for keeping your type organized.

Tweezers - for handling of individual type and spacer.

Preparing for Operation

Setting up your hand-operated SLE Hot Printer (Models M-800A, M-800B, M-800D, M-800E)

As you unpack the SLE Hot Printer, familiarize yourself with its contents. Save the carton and packing materials. They should be used to re-pack the machine for transportation or service if necessary.

1. Remove the machine from the bag.
2. Place the machine on a flat, level table. Make sure that machine is stable during operation.
3. Insert the Handle into the Handle Slot and tighten the Handle Lock Screw.

Setting up your air-operated SLE Hot Printer (AM-800A, AM-800B, AM-800D or AM-800E)

The air-operated machine is identical to the hand-operated model. The difference is that air pressure does the work. Instead of pressing a handle, the mechanism operates with two Activation Buttons. For the special application of imprinting ribbons, a cycle mode allows the machine to operate automatically and only one hand is needed to feed the ribbon.

Your SLE Hot Printer comes in two boxes. Box one contains the machine, the Pneumatic Control Box and accessories. Box two contains the compressor. To set up your air-operated machine:

1. Set up the compressor according to the instructions included in the box. Place the compressor on the floor underneath your table. **IMPORTANT!** Be sure to install the air filter and add oil to the compressor before operation.
2. Place the Pneumatic Control Box on a flat table surface where you will be working. Insert one end of the black tubing into the pressure regulator of the compressor. Insert the other end of the tubing into the back of the Pneumatic Control Box ("air inlet".)
3. If you use a compressor other than the Super-Quiet Compressor supplied by us, you need to lead a 6mm O.D. tubing from your compressor to the air inlet at the back of the Pneumatic Control Box.

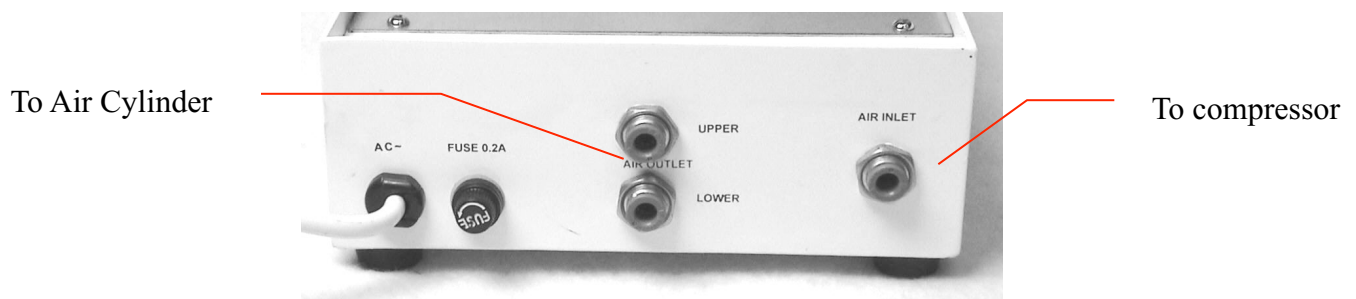

4. Place the machine on top of the Pneumatic Control Box. Your machine comes with a braid of two tubing. One has a label "Upper" and the other has a label "Lower." Insert the two tubing into the back of the Pneumatic Control Box. ("Upper" to "Upper", "Lower" to "Lower".)
5. Plug the machine, the Pneumatic Control Box and the compressor into the proper electric outlet and turn on the power switches.
6. Allow time for the air pressure to build up in the compressor.
7. Set the pressure needed for imprinting on the Pressure Regulator. Pull the round knob upward, then turn to set pressure. Press the knob down when finished.
8. Your air-operated SLE Hot Printer is now ready for operation.

Loading Foil

Depending on your specific model, the SLE Hot Printer is designed to accommodate foils from one to six-inch width. The foil is automatically advanced with each impression.

1. Remove the outer Foil Holding Socket from the Rear Foil Bracket by turning it clockwise and pulling outward.
2. Remove the outer plastic Foil Holding Disc. Leave the inner disc on the Rear Foil Bracket.
3. Remove the label from the foil and mount the foil onto the Rear Foil Bracket with the foil unwinding downward from the front of the roll.
4. Replace the outer Foil Holding Disc.
5. Replace the outer Foil Holding Socket to lock the foil in place by pushing the Socket in along the groove and turning it counter-clockwise.

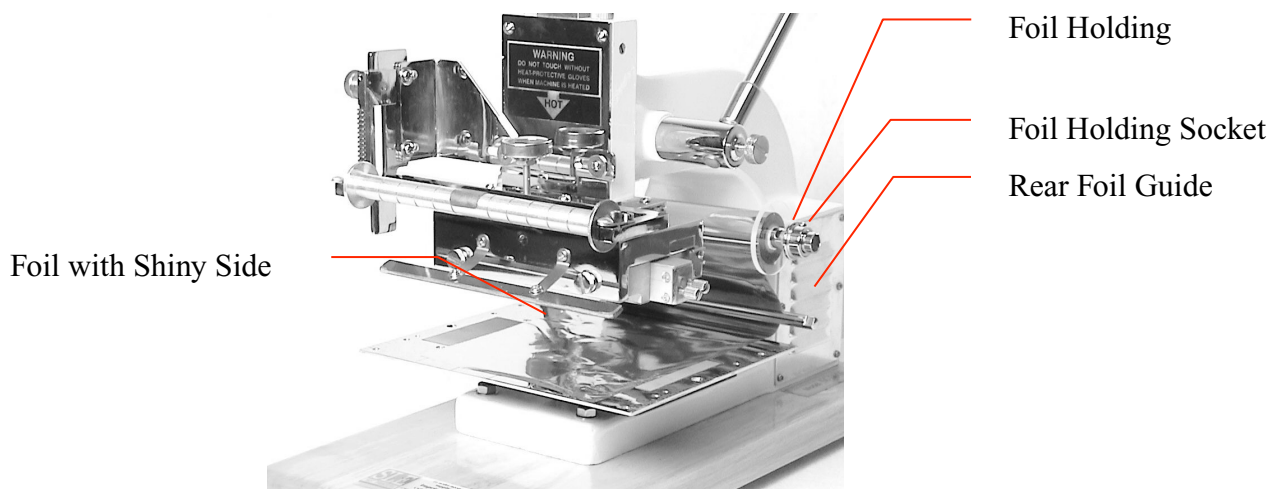

6. Center the foil by adjusting the position of the inner and outer Foil Holding Sockets.
7. Slip the foil under and around the Foil Guide Bar with the aid of a pencil. Pull the foil towards the front of the machine. At this point check to verify that the dull side of the foil is facing downward. (If the shiny side is facing downward instead, go back to step 3 and mount the foil in the reverse direction.)

8. Snap the metal Foil Clip from the Foil Take-up Spool and wrap the end of the foil (dull side facing in) around the spool.
9. Replace the Foil Clip over the foil

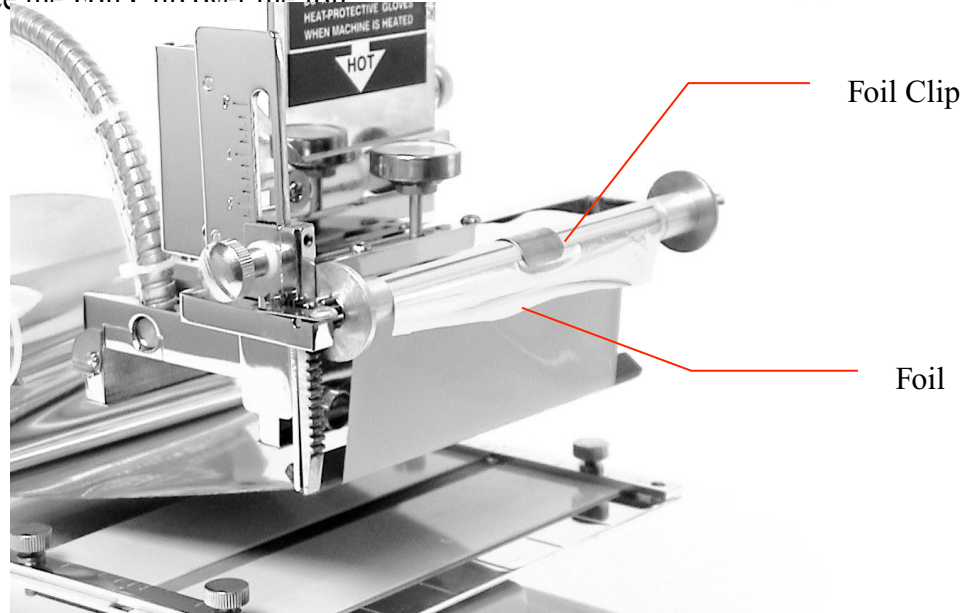

CAUTION:

- During operation, the Heater Platen can become very hot. Take extreme caution when loading or unloading foils.
- When setting up or changing foil on air-operated units, always turn off power to the Pneumatic Control Box.

Setting Foil Pull

The purpose of setting the foil pull is to make sure that each printing impression is made on new foil. Proper adjustment of the foil-advancing mechanism will automatically advance the right amount of foil, thus preventing waste.

1. Loosen the thumbscrew locking the Foil Rack Assembly at the left side of the Foil Take-up Spool.

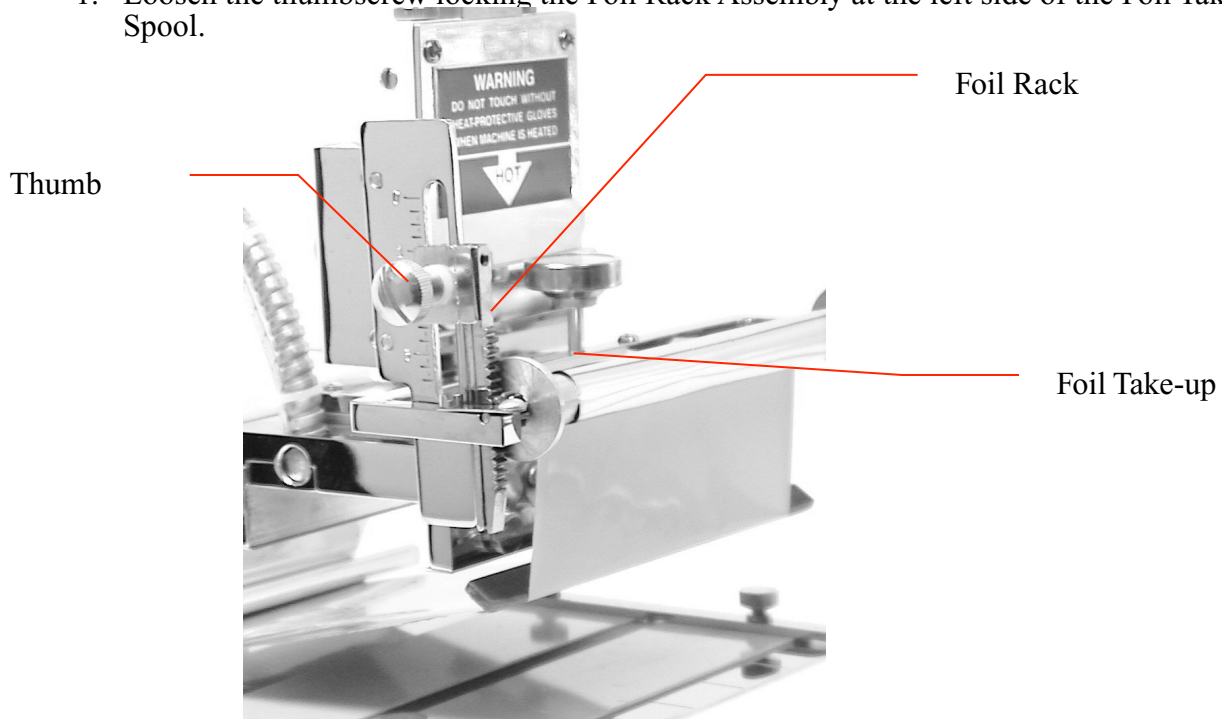

2. Raise or lower the Foil Rack Assembly to adjust the amount of foil pull. For maximum foil pull the Rack should be set all the way down. For minimum foil pull, the Rack should be set all the way up.
3. When you have adjusted the Rack to the desired setting, tighten the thumbscrew to firmly lock it in position.

Unloading Used Foil

During operation, used foil will build up on the Foil Take-up Spool. This tends to alter your foil pull periodically.

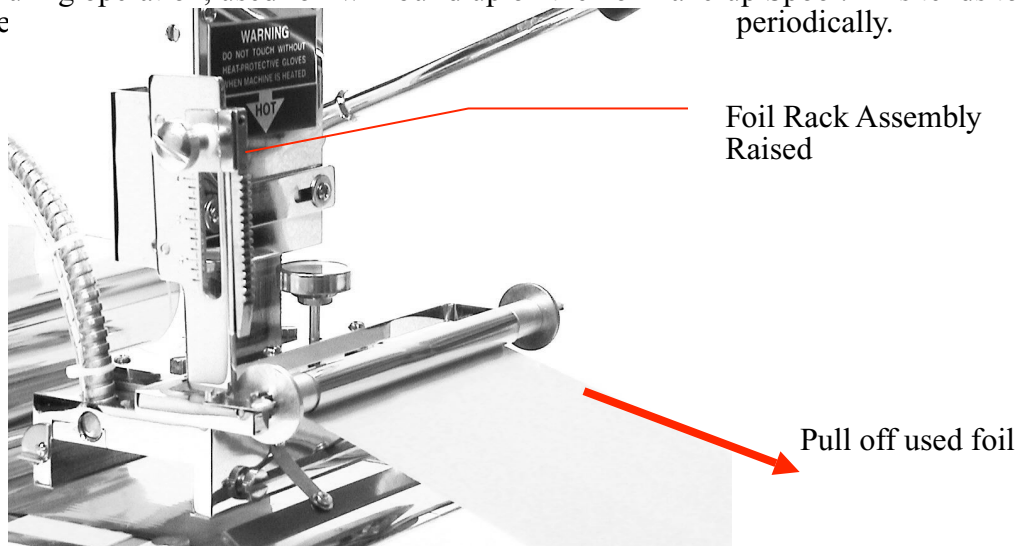

1. Raise the Foil Rack Assembly to the top-most position.
2. Cut the foil just underneath the Foil Take-up Spool.
3. Press the Machine Handle down slightly with your right hand while pulling the used foil off the spool using your left hand.
4. Snap the metal Foil Clip from the Foil Take-up Spool. Discard the used foil.
5. Wrap the end of the new foil (dull side facing in) around the spool.
6. Replace the Foil Clip over the foil.

SETTING THE TEMPERATURE

Before you begin imprinting, you need to set the temperature of your SLE Hot Printer. Temperature is regulated by rotating the small Regulator Knob on the controller, at the rear, left side of the machine.

In general, SLE foils are formulated to perform best within a temperature range of from 200 to 250 degrees, depending on the type of material being printed. Smooth, coated papers perform well at the low range, while textured stocks require higher temperatures.

It is not possible to recommend a given temperature for any particular substrate to be imprinted because of the various production conditions that are encountered. The affecting factors are:

- Formulation of the foil
- Surface to be imprinted; coarse or smooth
- Pressure applied
- Dwell time
- Type style used; light face vs. bold face
- Ambient condition

The following table is a guide in determining the proper setting, based upon the type of material being imprinted. These readings, however, are only approximates and may require minor adjustments to achieve the optimal result. To ensure a good imprint, it is recommended that you set the temperature slightly lower in the beginning, and increase as necessary.

TEMPERATURE TABLE

Regulator Knob Setting	1-3	3-5	5-7
Temperature (°F)	190-230 (88 °C-110 °C)	230-260 (110 °C-127 °C)	260-280 (127 °C-138 °C)
Applicable Substrates (for reference only)	Mylar, leather, PVC	Ribbon, paper	Plastic, wood

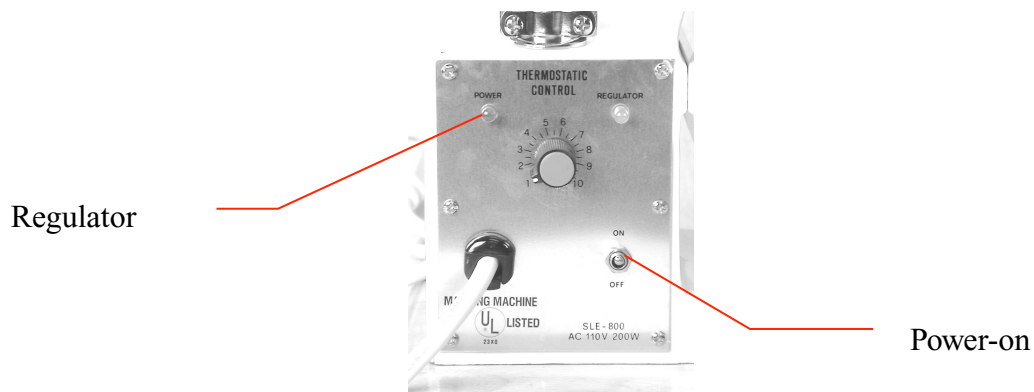

1. Plug in your SLE Hot Printer and turn on the power. (The Green and Red lights come on.)
2. Turn the Regulator Knob to the appropriate scale according to the above table. When the temperature has reached the set point the green light on the temperature control panel will begin to flash, on and off.
3. When the flashing begins, wait another minute or two for the heat to reach the typeface, then proceed to make a test print.

Preparing the Type, Emblem, or Die

After setting the temperature on your SLE Hot Printer, the next step is to prepare the type, emblem, or die. Setting type is a surprisingly simple procedure. With a little practice, it can be mastered by almost anyone. Do not rush; speed will come with practice.

Here is a short primer to help you become conversant in type setting:

- Types are die-cast letters and numbers used to create personalized text.
- An emblem is a diecast piece of type incorporating a symbol or artwork that can be set next to the type.
- Magnotypes are similar to type but with a complete word or phrase cast in a single piece to make type setting less time consuming.
- A die is larger piece of artwork (such as a company logo) photoengraved and mounted on an aluminum wafer or block. Dies are usually set in specialized Die Holders. Several die holders are available for specific applications.
- Type size is measured in points. There are 72 points to an inch, so 18-point type is equal to 1/4 inch and 12-point type is equal to 1/6 inch.
- SLE offers a wide selection of type styles in several different sizes. Consult the SLE listing of type styles for the ones that best suit your requirements.
- If you examine a piece of type, you will see a deep notch on one of the long sides. This is called the "nick." Most types have only one nick, but some types have three nicks. The nicks denote the bottom of the typeface.
- In order to achieve a printed impression from type (or emblem), individual letters must be set by hand to form the text to be printed. The normal way of setting Type is to place each piece of type into a Type Holder that holds the type together. SLE offers several Type Holders; each designed to perform specific tasks in the most efficient manner. Choose the appropriate Type Holder based on the requirement of your specific print job.
- Type is set line by line in the same sequence as they appear in the copy. This means you set the type from left to right, starting with the first word of the first line and ending with the last word of the last line. When setting type into the Type Holder, the nicks usually should face UP, thus making the letters appear upside down.
- When setting type please make sure that the feet of all the type are in good contact with the Type Holder, and make every effort to center the type in the Type Holder, as nearly as possible. Centering will ensure even printing pressure on each character, resulting in higher quality printing.
- Never mix new type with old ones.
- The spaces at the end of each line and those between words must be filled up with spacers that do not actually show up as print. Always use spacers of the same point size as that of the type being set. For example, 12-point spacers must be used with 12-point type; 18-point spacers must be used with 18-point type, etc. Spacers of different point sizes should never be mixed.
- When using an Open Chase Type Holder, lead rules are used to separate different lines of type, to increase the space between lines and for centering. Lead rules (pronounced "led") are flat metal strips that come in various thickness and lengths. They can be placed laterally against either side of the Type Holder and may be used with all sizes of type.

- Do not leave type in a hot machine for an extended period of time. As soon as you have finished printing, remove the Type Holder from the machine and return the type back into the type box.

The following instructions are intended to aid those who have little or no experience with typesetting. As one gains experience in setting type, different ways of shortening the process will become apparent.

Printing with a 1-Line or 2-Line Type Holder

In many printing jobs, the print run may be limited to one or two lines. Although one or two line jobs may be accomplished with a 2-Line Type Holder, many prefer the convenience and simplicity of the 1-Line Type Holder, with ribbon printing is best done with a 1-Line Type Holder.

The 1-Line or 2-Line

One-Line Type

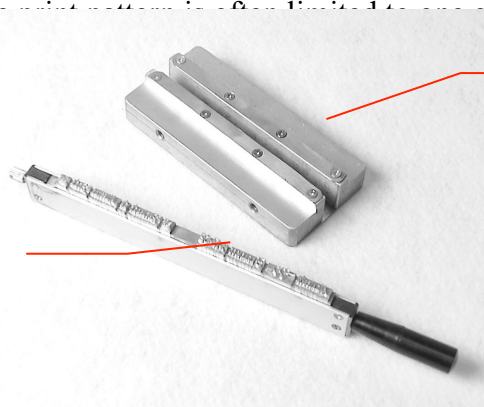

holder, many prefer the convenience and simplicity of the 1-Line Type Holder, with ribbon printing is best done with a 1-Line Type Holder.

The 1-Line or 2-Line Type Holder and its corresponding Adapter Sleeve.

1. Insert the Adapter Sleeve into the Heater Platen and lock it by flipping the Butterfly Clips on the side of the Heater Platen.
2. Hold the Type Holder with the handle pointing towards your left. Set your type onto the Type Holder from left to right with the nick facing UP. The letters will appear upside down.
3. After the type is set, add spacers (starting with large spacers first) on either side of your type to fill in the blank spaces while keeping the type centered.
4. Tighten the thumbscrew(s) on the right of the Type Holder to hold the type in place.

CAUTION:

- You should only turn the screws until they stop. Over tightening can damage the type and the Type Holder. If you find it necessary to use a small screwdriver to aid in tightening the thumbscrew(s), be sure to never exceed 1/8 of a turn.

Type

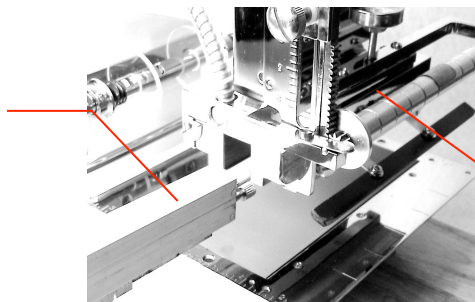

Adapter

5. Insert the Type Holder into the Adapter Sleeve. When imprinting at the top of a page, such as on stationery, insert the Type Holder from the left side of the Adapter Sleeve. When imprinting at the bottom of a page, such as on greeting cards, insert the Type Holder from the right side of the Adapter Sleeve.
6. Remove the Handle from the Type Holder. Allow the type to heat up before imprinting.

NOTES:

- To remove an Adapter Sleeve, use a pencil and push the Adapter out of the Heater Platen. Always use a Holding Pad as the Adapter Sleeve can become very hot.
- Always remove the Type Holder from the machine and loosen the screws when you are through imprinting. Type last longer when it doesn't cool under pressure.

Printing with the Open Chase Type Holder

The Open Chase Type Holder is used for multi-line print jobs. A typical application is printing on paper napkins.

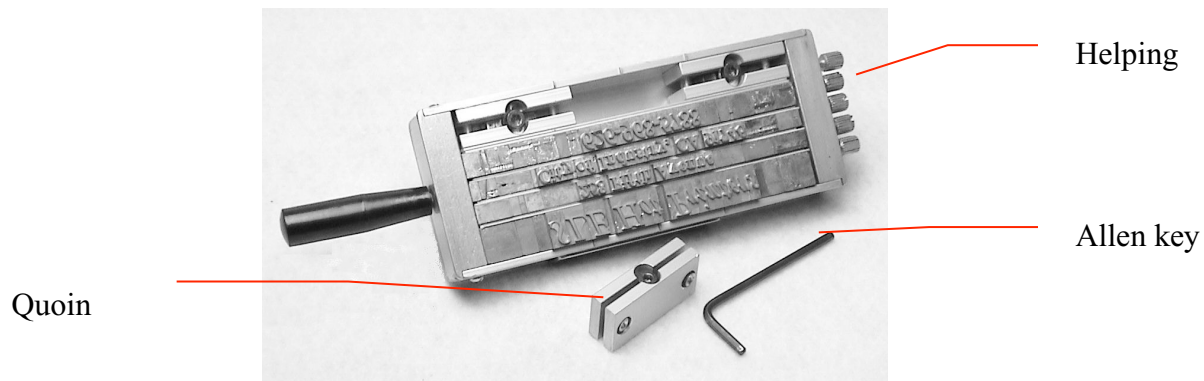

1. Place the Type Holder onto the typesetting stand with the open side facing you and the handle pointing to the left.
2. Place one or more lead rules into the holder, to achieve the desired starting distance from the side of the holder.
3. Beginning from left to right, position the first character of the first word, with the nick facing upward. The letters will appear upside down. Use the tweezers (furnished with your accessories) to facilitate the handling and placement of the individual type.
4. Continue adding characters in the normal spelling sequence, until the first word is complete.
5. Place a spacer after each word to create a clear separation of words.
6. Continue the procedure until the first line is complete. If space remains, shift the completed line toward the center of the holder and fill the end openings with spacers.
7. Place one or more lead rules on top of the first line, to create the desired space between the first and second line. If you prefer less space between lines you may eliminate the lead rules altogether.
8. Continue the same procedure for each succeeding line. Complete the setup by placing at least one lead rule atop the last row of type. Be sure to leave enough space for the Quoins.
9. Place the Quoin(s) in position to lock the type.

10. Carefully study the setup to be sure there are no mistakes. Add lead rules where necessary to center the print pattern.
11. When satisfied that the setup is correct, gently tighten the Helping Screws at the end of the holder to secure each line of type. You should only turn the screws until they stop. Over tightening can damage the type and the Type Holder. It is not necessary to use a screwdriver for this purpose. Do not tighten those Helping Screws that are hitting against a lead rule.
12. Lightly press the top of each character with your forefinger, to verify that each one lies firmly against the bottom of the Type Holder.
13. Expand the Quoin(s) with an Allen key in the clockwise direction until the type is held securely in the holder. Do not over tighten as this may damage the type or Type Holder.
14. Insert the Type Holder into the Heater Platen. When imprinting at the top of a page, such as on stationery, insert the Type Holder from the left side of the Heater Platen. When imprinting at the bottom of a page, such as on greeting cards, insert the Type Holder from the right side of the Heater Platen.
15. Remove the Handle from the Type Holder. Allow the type to heat up before imprinting.

PRINTING WITH ENGRAVINGS

Some imprinting job may include a graphic design or engraving. Used in combination with standard typesetting, special engravings can add the "professional touch" that appeals to both business and social customers and opens the door to a wide array of possibilities for those wishing to expand their market.

Engraving dies, in the form of a metal wafer, can be produced from virtually any calligraphic or graphic design. These Wafer Dies, if used alone, can be made to fit a number of specially designed Die Holders or, if used together with type, can be made to fit the WHOC (Wafer Holder for Open Chase).

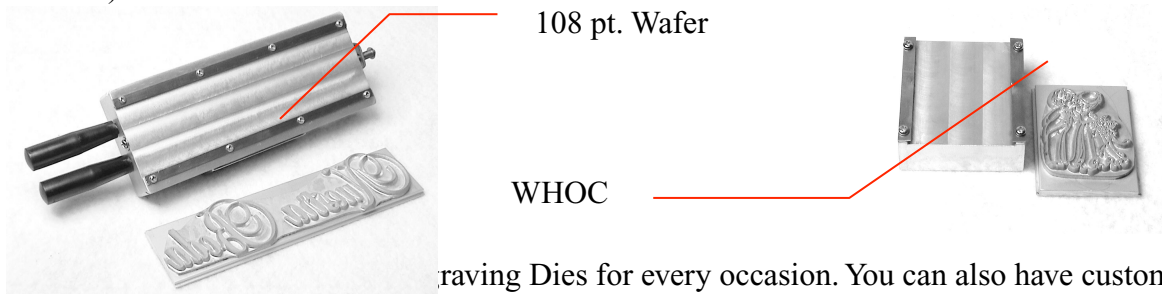

108 pt. Wafer

WHOC

Engraving Dies for every occasion. You can also have custom dies made from your own design by simply sending us your black-and-white camera-ready artwork. When you prepare your artwork, try to use line drawings and avoid large areas of solids. Solid areas will not produce satisfactory results.

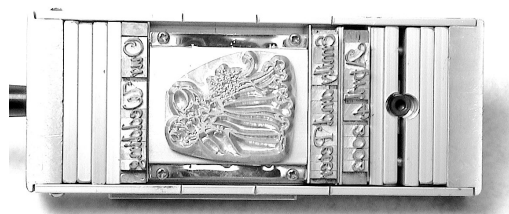

Combining engraving with set type.

To combine an engraving with set type, simply slide the Wafer Die into the WHOC. Set the type using the Open Chase Type Holder and then drop the WHOC into the Type Holder. Complete the setup with spacers and lead rules and secure it with the Quoins. Insert the Type Holder into the Heater Platen as usual.

Doing Test Imprints

Before imprinting any merchandise, always make a test imprint to check spelling and imprint quality.

The three essential factors for a quality foil imprint are the proper: TEMPERATURE, PRESSURE and DWELL.

TEMPERATURE Temperature is controlled by the setting you select on the controller and monitored by an easy to read Temperature Gauge.

PRESSURE Pressure is controlled by how hard you press on the Handle on a handle-operated machine, and by the air pressure regulator on an air-operated machine.

SOME NOTES ON PRINTING PRESSURE

- The correct amount of pressure applied by the type against the article to be printed is essential for high quality printing. Too much or too little will produce results that are unsatisfactory.
- Soft papers, smooth ribbons, vinyl's, leathers and plastics, require less pressure. Materials with slight texture will require somewhat more pressure. Materials with pronounced textures, in most cases, should be avoided.
- Sometimes a careful choice of type style can overcome the problems associated with texture. Medium to heavy textures might be successfully printed provided the type size is not too small, and that the type style has been designed with thin, light lines. The printing surfaces of such type are sharper, making it easier to penetrate heavier textures than a type design with heavier strokes.
- In addition, the printing area will have a definite influence on how much pressure to apply. The heavier or more massive the printing area, the greater the pressure required. Lighter and smaller printing areas require less pressure. For example, if the print pattern contains five or six lines of type, somewhat more pressure will be required than if it contains only two or three lines of the same, or similar, type size.
- It is, therefore, important that careful consideration be given to the texture of the material being printed, and to the size and density of the type/engraving being used. All of these factors have a direct bearing on the amount of pressure required to produce the desired results, or whether the desired results can even be achieved.

DWELL TIME Dwell is the amount of time needed for pressing the hot type against the foil to get a desired impression. The proper dwell time allows the foil to release evenly at all points on the printed surface. The user controls the dwell time on a hand-operated machine. On an air-operated machine, the setting you specify on the electronic timer controls the dwell time.

1. Release the Side Screw and adjust the Gauge bar to fix the position for the article(s) to be imprinted.

2. Position the article on the Printing Table. Substitute a piece of scrap paper for the actual article if necessary.
3. For the correct imprinting pressure, always apply the pressure in two motions:
 - Bring handle down with light, easy motion, with arms and finger relaxed until the type is almost touching the article to be imprinted.
 - Press down harder and hold for short (1 or 2 seconds) dwell.
 - Release the pressure, and gently bring the handle back to the starting position. Do not let handle snap back.
4. Check the copy for errors in spelling.
5. If the position of the imprint is not satisfactory, release the Side Screw and adjust the Gauge bar to re-position the article to be imprinted.

For Air-operated units:

- Pressure is controlled by setting the pressure regulator on the compressor.

Clockwise	= increase pressure
Counter-clockwise	= reduce pressure

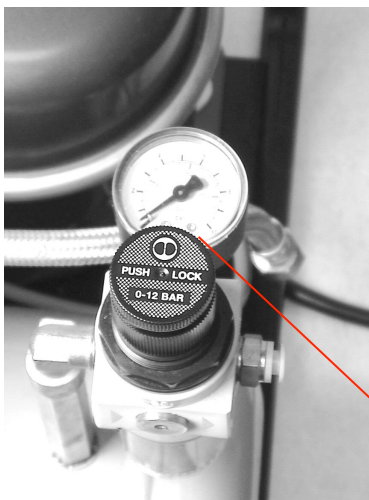

Dwell

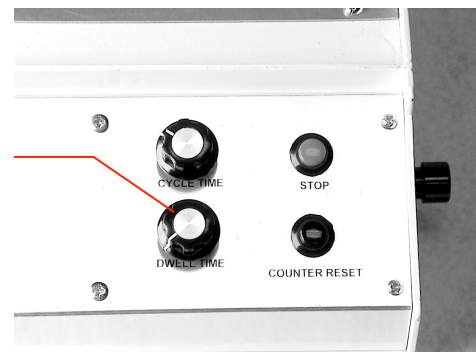

Pressure Regulator

- Dwell time is control by turning the Dwell Time dial on the front panel of the Pneumatic Control Box.

Clockwise	= longer dwell time
Counter-clockwise	= shorter dwell time

- Activate machine by pressing the two red Activation Buttons simultaneously.

If You Need Help

If you do not get perfect imprints, read this instruction book over again very carefully and look at the Training Video. If this does not help, write to us at 258 Fifth Avenue, City of Industry, CA 91746. Describe what seems to be the trouble. Enclose samples of your product, a section of the used foil and mark down the temperature used. Our Service Department will help you by return mail.

Common Problems & Solutions

The basic factors that contribute to creating quality imprints are: Temperature, Pressure and Dwell time. The following section offers solutions to most of the problems encountered in hot stamping.

PROBLEMS

SOLUTIONS

A) *No Impression at All*

- Machine is still cold
- Foil is loaded upside down up.
- Type Holder is obstructed
- Machine handle not pressed down completely

Allow more time for the machine to heat up

The foil should always be shiny side

Re-adjust the attachment(s)

Press down harder on the Handle

B) *Faint or Weak Impressions*

- Temperature is too low.
- Insufficient pressure or dwell time.
- Not enough foil pull
- Inappropriate foil

Set higher temperature.

Allow more time for the type to heat up.

Press Handle slightly harder or a little longer.

Adjust the Foil Rack.

The foil you are using may be inappropriate for the material being marked. Refer to the section in this manual on proper foil selection.

Some foil releases at different temperature than others. Be sure to get the temperature just right for the foil you are using.

Some foil requires a shorter dwell time than others, especially when using fine line type. Brilliant colors imprint clearer than pigment on soft papers, napkins, etc.

C) *Smearly Impressions (plugged up letters)*

- Too much heat.
- Too much pressure or dwell time.

Reduce temperature.

Go easier on the Handle.

* Sometimes blurred impressions may be brushed clean with a soft cloth.

D) *Uneven or Spotty Impressions*

- Type Holder is not hot enough.
- Type in Type Holder is not level.

Allow more time for Type Holder to heat up evenly.

Loosen the screws on the Type Holder and tap gently until type rest evenly against the bottom of the type holder. Tighten screws again.

- Different height of type due to mixing of type from different type sets. Do not mix old type with new type.
- Worn or damaged type Replace with a new type set.
- Worn cushion board on Printing Table Replace cushion board.
- Foil overlapping Increase foil pull by adjusting the Foil Rack.
- Inappropriate foil for this application Try another foil.
- Insufficient pressure. Press Handle slightly harder,
- Printing Table unlevelled Adjust printing table using the following procedure.

Adjusting the Printing Table

Because of various uncontrollable factors, such as vibration, uneven die mounting, etc., it may become necessary to adjust the level of the machine table in order to achieve even impressions.

1. Release the Locking Screw underneath the Wooden Base.

Locking

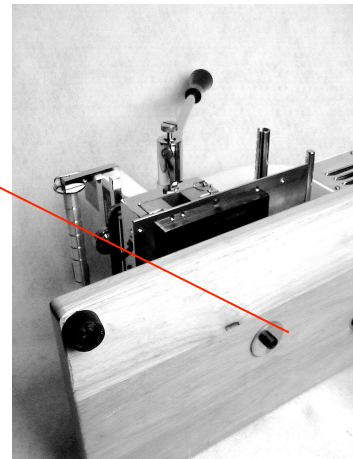

2. Make a test imprint on a card.

3. Based on the result of the test imprint, decide which corner of the printing table needs adjustment. Too strong an impression on one corner, relative to the other corners, means the table needs to be lowered. A weak impression means the table needs to be raised.

4. Turn the appropriate Hexagon Nut(s) underneath the Printing Table with the supplied wrench.

- Clockwise = Raise table
- Counterclockwise = Lower table

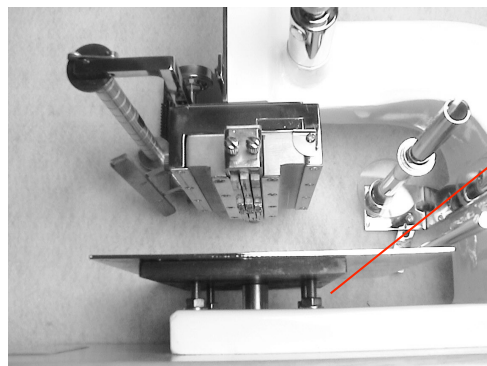

Hexagon

5. Make another test imprint and examine the result.
6. Adjust table again by turning the appropriate Hexagonal Nut(s).
7. Repeat this process until you get an even impression on all four corners of the test imprint.
8. After adjustment, tighten Locking Screw underneath the wooden base.

E) ***Foil Sticking To Item After Imprinting***

- Too much heat or dwell time too long. Reduce temperature.
Go easier on the Handle.
Remove the item sideways not towards you after each impression.

F) ***Foil Feed Problems***

- Foil does not rewind at all Check whether the Saw-Edged Bar on the Foil Rack Assembly is in proper contact with the Gear on the Foil Take-up Spool. In case adjustment is needed, loosen the two hex screws, shift the Foil Calibration Plate forward or backward and lock the screws again when proper contact is established.
- Foil has difficulty pulling forward. Make sure that the foil rolls freely on the Rear Foil Bracket. Adjust the position of the Foil Holding Socket as necessary.
- Foil Take-up Spool rolls back and forth The Foil Take-up Spool may be too loose. Increase the pressure on the Foil Tension Springs by slightly tightening the two Foil Tension Screws. Do not over-tighten.
- Too much foil pull Adjust the position of the Foil Rack Assembly
- Foil pull increases after a few jobs Too much used foil build-up on the Foil Take-up spool. Unload the used foil.

Special Imprinting Applications

Now that you have mastered the basics of foil stamping, we shall explore the techniques that pertain to specific applications.

How to Imprint on Ribbons

Imprinted ribbons are used to decorate party favors, gift baskets and trophies to get a personalized message across. Your SLE Hot Printer is the most advanced of its type available for printing ribbons. It features a built-in ribbon guide that is very precise and easy to set up. The extra wide Type Holder allows you to print both sides of a favor ribbon in just one pass.

1. Set the temperature to about 220 degree.
2. Slide the 1-line Adapter Sleeve into the Heater Platen.
3. Set the 1-Line Type Holder according to the instructions above on typesetting. The most common type sizes used for ribbon printing are 12, 14 or 18 points. Use P-series or A-series foil for these Type sizes.
4. Insert the Type Holder into the Adapter Sleeve from the left.

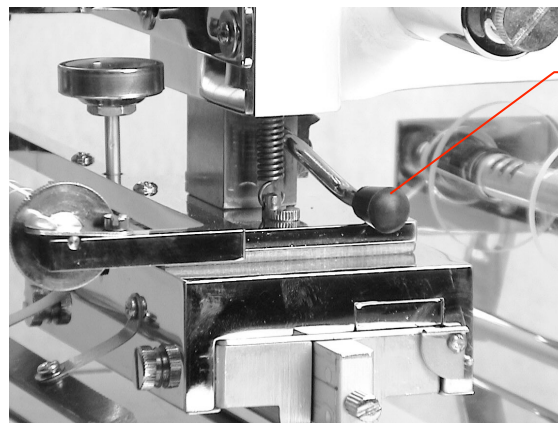

Stop Pin

5. Insert the Stop Pin into the side of the Ram Bar. The stop pin cuts down the amount of work you do by reducing the distance your arm travels.
6. Adjust the foil pull.
7. Secure the Ribbon Spindle onto the wooden base on the right side of the machine
8. Install a spool of ribbon onto the Ribbon Spindle.
9. Release the thumbscrews on the built-in ribbon guide.
10. Expand the Ribbon Guide by sliding the yellow plastic plate forward.
11. Thread the ribbon through the Ribbon Guide between the two yellow plastic plates and underneath the two metal bars.
12. Center the ribbon by adjusting the position of the two yellow plates to make sure that the ribbon passes directly underneath the type. Make sure that the type does not hit any part of the Ribbon Guide during operation. Tighten the thumbscrews to secure the position of the Ribbon Guide.

Setup for Ribbon Printing



13. Make a few test prints, and make any necessary adjustment to the ribbon guide until the impression prints in the center of the ribbon. Adjust the temperature as necessary.
14. When printing ribbons, use strong and short dwell.
15. After each imprint, pull the ribbon through with your left hand.
16. To control the distance between impression (e.g. 12 inches):
 - Cut a piece of masking tape and place it on the table 12 inches from the left edge of your printing table. This is your marker.
 - When pulling the ribbon, use your left thumb and index finger and grab the ribbon at the edge of the printing table.
 - Pull the ribbon until your left thumb reaches the marker.
17. When finished imprinting, cut the ribbon into individual pieces or rewind onto the spool using the Ribbon Spindle.

NOTE:

- If there is excess foil surrounding the impression while imprinting ribbons, you might be able to salvage your work by simply wiping it off with a piece of soft cloth.

How to Imprint on Ribbons using air-operated machines.

1. Set up machine as above.
2. Set the air pressure to 80 psi at the compressor.
3. To do test imprints, activate machine using the two red Activation Buttons.
4. Check the quality of the test imprints. Adjust temperature, pressure or dwell time as necessary.
5. When you are satisfied with the quality of the test imprints, switch machine to Cycle Mode. Slide the Cycle Mode switch forward. Cycle Mode Indicator starts blinking.

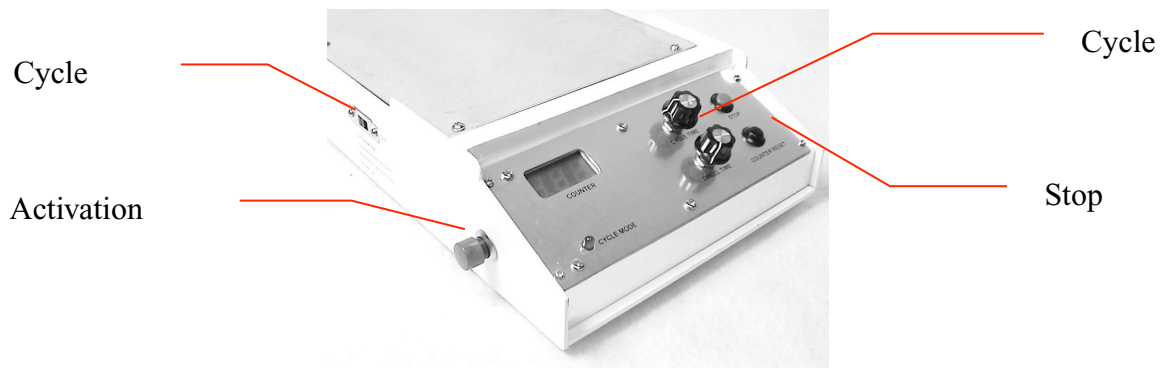

6. Activate machine by pressing once on the two Activation Buttons.
7. Pull ribbon towards the left using your thumb and index finger.
8. To adjust the printing speed, turn the Cycle Time Knob on the control panel
Clockwise = slower
Counter-clockwise = faster
9. Stop machine by pushing the Stop Button
10. When finished imprinting, switch off cycle mode by sliding the Cycle Mode switch backward.

CAUTIONS:

- Never place your hands on the printing table during operation of the machine.
- For air-operated units, never use the cycle mode for any application other than ribbon imprinting. Always turn off the cycle mode when not in use.

How to Imprint on Napkins

Napkins are available in beverage or luncheon styles. Beverage napkins are approximately 5 inch square; luncheon napkins are approximately 6 1/2 inch square.

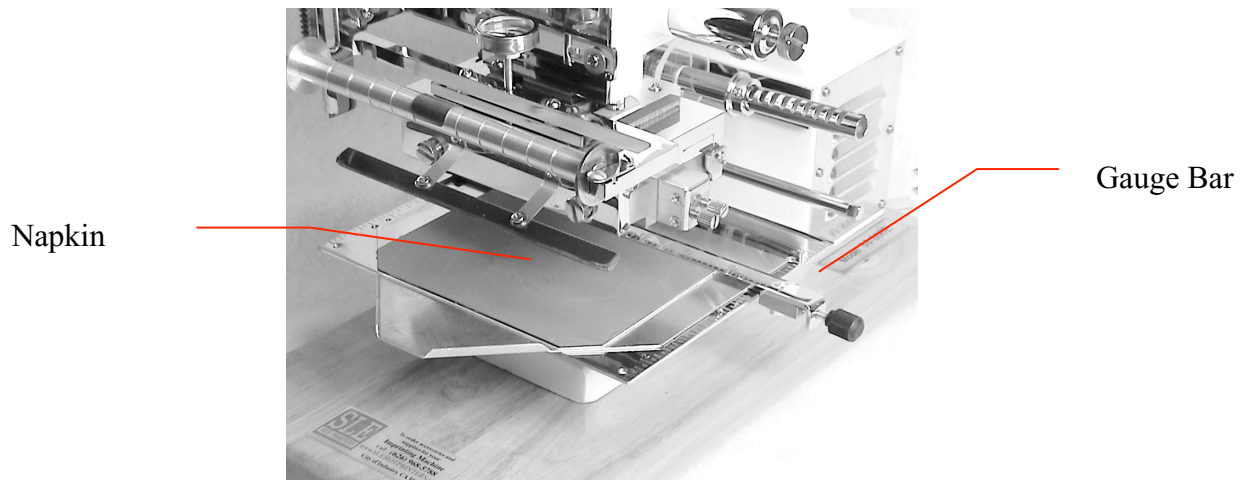

1. Set the temperature to about 230 degrees.
2. Set the Type using the Open Chase Type Holder or the 2-Line Type Holder according to the instructions on typesetting. The most common type sizes used for napkin printing are 18, 24 or 36 points. For best results, use H-series or A-series foil for napkin printing.
3. Insert the Type Holder into the Machine.
4. Secure the Napkin Guide on the Printing Table using the Gauge Bar.
5. Place the napkin in the Napkin Guide.
6. Make imprints using firm, medium dwell. Adjust temperature as necessary.
7. Remove the napkins.

NOTE:

- Some foil may have a tendency to stick to soft materials (3 ply napkins). If this occurs, merely remove merchandise sideways. Do not pull forward.

How to Imprint on Matchbook Covers

Matchbook covers can be imprinted straight on or at an angle. Select the proper Matchbook Guide as needed.

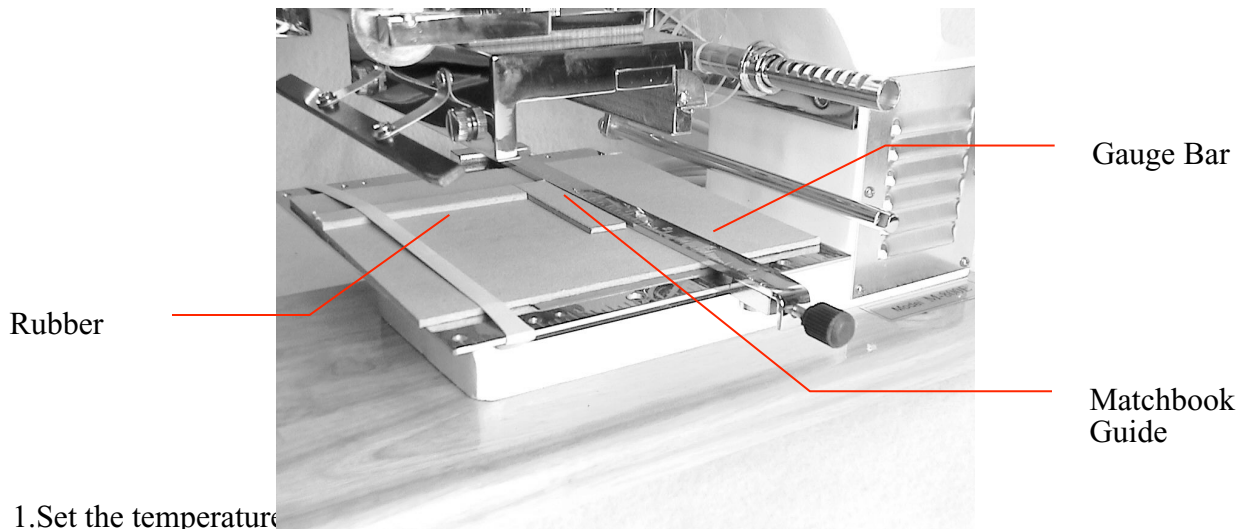

1. Set the temperature
2. Set the 2-Line or 3-Line Type Holder according to the instructions on typesetting. The most common type sizes used for matchbook printing are 12 and 14 points. Use P-series or A-series foil for this project.
3. Insert the Type Holder into the Adapter Sleeve.
4. Secure the Matchbook Guide on the Printing Table using the Gauge Bar.
5. Wrap a rubber band around the front of the Printing Table to assist in holding the matchbook in place.
6. Open the flap of the matchbook, slide underneath the rubber band and place onto the Matchbook Guide.
7. Bring the handle down and imprint with a short dwell.
8. Remove the imprinted matchbook and close the cover.

CAUTIONS:

- Never stamp a closed matchbook. This could result in a fire.
- Keep the matches away from the heated part of the machine.

How to Imprint on Pencils

Hexagonal pencils can be imprinted by using the specially design Pencil Attachment.

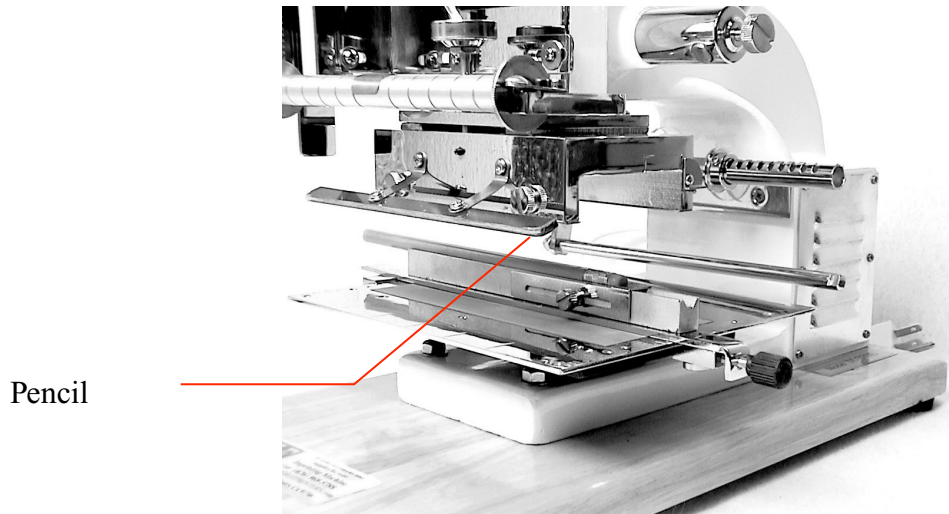

1. Set the temperature to about 210 degrees. Adjust temperature as necessary.
2. Use Cheltenham 9-point Type and set the Type Holder according to the instructions above on typesetting. Use P-series foil for this project.
3. Insert the Type Holder into the machine.
4. Secure the Pencil Attachment onto the Printing Table.
5. Load the pencil into the attachment from left to right, eraser end first until it is flush with the right side of the attachment.
6. Pull the Handle down gently to print. Imprinting pencils takes a gentle touch. Use only one finger pressure and let the heat do the work.
7. Use another pencil to push out the imprinted one.

How to Imprint on Stationery, Invitations or Announcements.

Stationery and writing papers can be imprinted using the Gauge Bar (for smaller stationery) or the Extended Printing Table (larger items.)

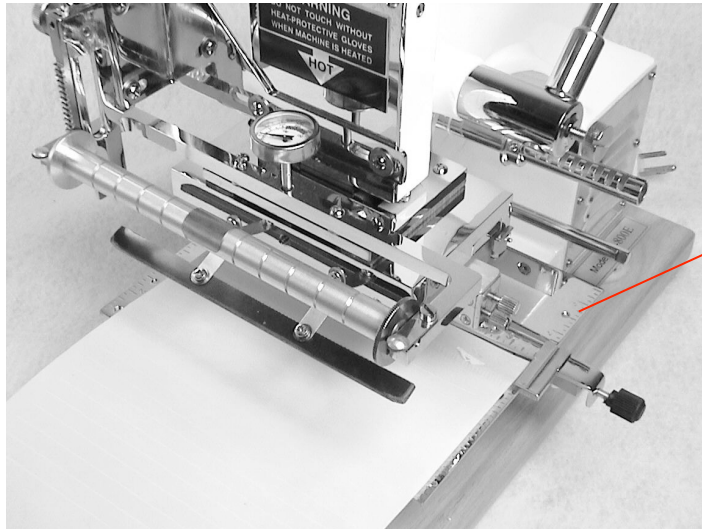

Gauge bar

2. Set the appropriate Type Holder according to the instructions on typesetting. Use P-series or A-series foil for smaller letters and H-series foil for larger letters or rough surfaces.
3. Insert the Type Holder into the Machine. When imprinting at the top of a page, such as on stationery, insert the Type Holder from the left side of the Adapter Sleeve. When imprinting at the bottom of a page, such as on greeting cards, insert the Type Holder from the right side of the Adapter Sleeve.
4. Slide the Gauge Bar onto the Printing Table and lock into the desired position.
5. Measure the width of the article to be imprinted.
6. Divide the width by two and place the Gauge Bar Clip at this number on either side of the zero on the Gauge Bar.
7. Place article onto the Printing Table and use the Gauge bar/Gauge Bar Clip for positioning.
8. Make a test imprint to check your spelling.

NOTES:

- To stamp a name at an angle across the corner, use the angle Matchbook Guide.
- When there is no foil that is a direct match to the ink used on your stationery, use a contrasting color such as gold or silver.

How to imprint on Emboss-a-Plates

SLE Emboss-a-Plates are vacuum plated in gold or silver with an adhesive backing. They are an excellent alternative for those who do not want to stamp directly onto photo albums leather bibles, as well as those hard to mark items such as centerpieces, desk sets or trophies.

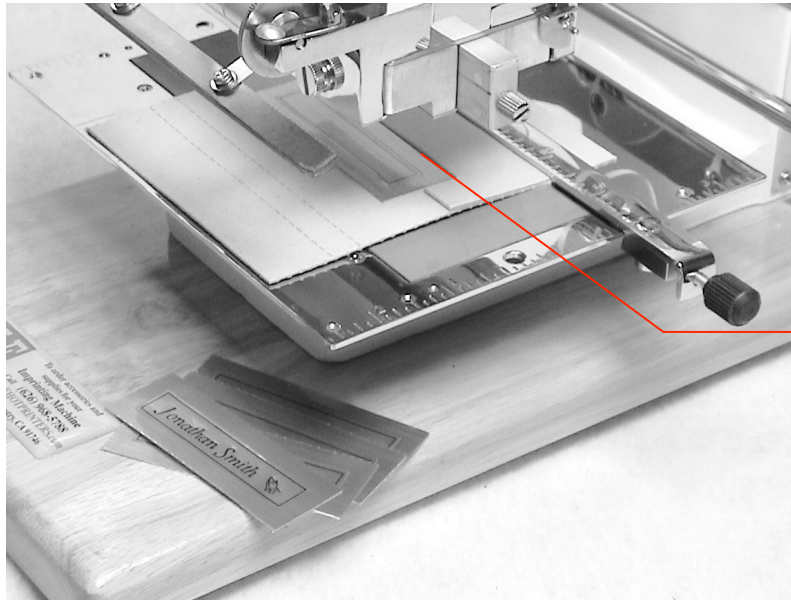

Emboss-a-

1. Set
2. Set the 1-Line or 2-Line Type Holder according to the instructions on typesetting. The most common type sizes for imprinting on Emboss-a-Plates are 12 and 18 points. Use A-series black foil for this project.
3. Insert the Type Holder into the Adapter Sleeve.
4. Secure the included Emboss-a-Plate Guide on the Printing Table using the Gauge Bar.
5. Place the Emboss-a-Plate onto the Guide.
6. Bring the handle down and imprint with firm pressure and medium dwell.

How to Imprint on Larger Items.

When imprinting larger items such as, satin pillows, albums, scrapbook covers, stationery, greeting cards, invitations and announcements, use the Extended Printing Table.

Because of its remarkable versatility, the Extended Printing Table is one of the most functional of all the SLE machine accessories. Properly used, the Extended Printing Table can dramatically increase production and enhance the print quality with significantly less effort.

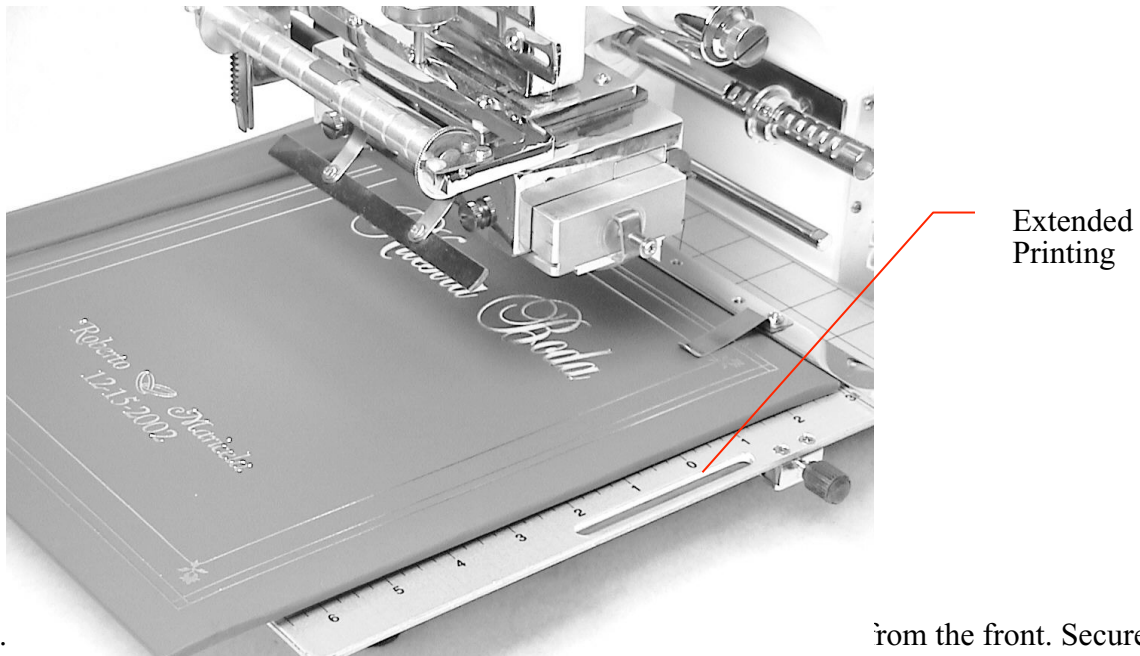

1. Place the article on the Extended Printing Table from the front. Secure in place by tightening the clamping screw on the right side.
2. Select the proper foil for the article to be imprinted. For satin pillows or albums use S-series foil. For paper articles use H-series foil.
3. Set the proper temperature for the article to be imprinted.
4. Set the Type Holder or Engraving Holder according to the instructions above on typesetting. Use larger type such as 36-point or 72-point.
5. Insert the Type Holder into the machine.
6. Position the article onto the Extended Printing Table. If necessary, secure with the long Gauge Bar.
7. Pull the Handle down to imprint.

How to Imprint on Mylar Balloons

To imprint on Mylar balloons, use larger type (36-point) and the H-series foil. Use the Napkin Guide for positioning.

1. Set the temperature to about 200 degrees.
2. Center the Napkin Guide on the Printing Table and lock into position with the Gauge Bar.
3. Place the balloon on the Napkin Guide, with the stem of the balloon pointing towards you.
4. Use a quick dwell for best results.

NOTE:

- If you are stamping 18" balloons, fold the balloon in half and then center it in the Napkin Guide or use the Extended Printing Table.
- Do not attempt to imprint on latex balloons. The results will not be satisfactory.

How to Imprint on Leather Articles

Imprinting on leather articles requires mastering some special techniques.

Temperature

- It is not necessary to use high heat for leather imprinting. Set temperature to 200 degree first and increase only if necessary.

Choosing the proper foil.

- For best results use our L-series foil specially formulated for leather articles. For less expensive items, use P-series foils.
- Sometimes removing the Foil Take-up Spool in the front will provide more room and a clearer view. When printing on leather items, you will most likely be using pieces of cut foil instead of using the automatic foil-advancing feature of your machine.

Choosing the proper type size

- It is difficult for some customers to visualize how the lettering they ask for is going to look on the finished product. For example, they may ask for extra long names on billfolds when just the initials would look neater and be easier to imprint.
- On rough leather, a larger type that makes a good, clear impression of just the initials is better than a smaller type that is difficult to read.
- It is very difficult to imprint with small size type on rough leather because the foil tends to fill in between the letters. If imprinting on rough grain leather, do not use type smaller than 12-point, and separate each piece of type with a thin brass spacer. This will prevent the letters from bleeding together.

Surface must be level and solid underneath.

- If the article to be imprinted is of uneven thickness, the name will not imprint evenly. For example, inside some billfolds there are extra pieces of leather running at an angle underneath the usual place for the name. To compensate for this, insert a piece of cardboard underneath to level it up.
- When imprinting books or albums, open the book and place only the cover on the Printing Table.

Secure article properly before imprinting

- Clamp object securely so it won't slip.
- Use the optional billfold clamp or a book clamp if necessary.

- Make sure the handle of the Type Holder does not interfere with the article you are imprinting. It is good practice to remove Type Holder Handles when imprinting.

Avoiding mistakes

- Place a swatch or a piece of cardboard over the article and make a test impression to check for spelling and alignment and to see if all letters print evenly.

Stamping without foil first

- Once you have positioned the article correctly and proofread your test impression, stamp the article without foil for a dwell of one second. This will form a smooth blind impression in the leather, allowing the foil to form a better bond. Do not move the article in any way after the blind impression.
- When imprinting rough leather, the trick is to stamp in the name several times until you get a perfectly clear and smooth impression before applying the foil.

Applying the foil

- Lay a piece of foil (dull side down) over the impression and stamp using a firm quick dwell. Check the used foil to see if you got a full release of the foil. If you did not get a clear impression, reapply foil and stamp over it again with a little more pressure or dwell. When you are satisfied with the result, you can remove the article from the machine.
- If there is excess foil surrounding the impression, merely wipe it off with a soft cloth. Use a moistened toothpick to remove surplus bits of foil between letters

How to Imprint on Favor Tags and Confetti Cards

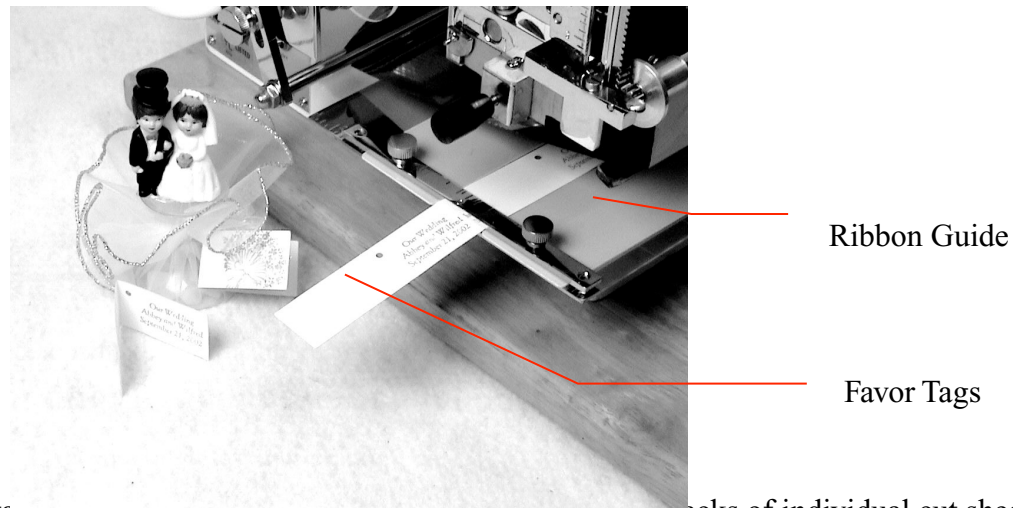

- Favor tags and confetti cards come in either of two forms, stacks of individual cut sheets or in a spool similar to a roll of postage stamps.
- For individual cut sheets, use the Matchbook Guide or Emboss-a-Plate Guide for positioning. (See the section above on imprinting Emboss-a-Plates.)
- For tags that that come in the form of a roll, handle them like you would a spool of satin ribbon. Load the spool of tags onto the Ribbon Spindle and use the Ribbon Guide for positioning.
- The best type to use for this project is 12-point type. Use the 3-Line 12-point Type Holder for this purpose.
- Imprint using either P-series or A-series foil, with medium short dwell.

How to Get Foil Imprinting Effects for Computer Output

For paper output from a computer or a photocopier, you can obtain the same elegant look of foil imprinting without even setting metal type or engravings. This can be accomplished by using the K-series specialty foil (Kopyfoil) and the Kopyfoil Attachment. The K-series foil essentially seeks out areas on your output where the original printing is in black ink and converts it to brilliant foil colors. Award Certificates, invitations and business cards are typical applications of this process.

1. Prepare the output using your computer or photocopier.
2. Insert the Kopyfoil Attachment into the machine.
3. Set the temperature to about 280 degree.
4. Lay the printout on the Printing Table.
5. Place a piece of K-series foil on top of the area that you would like to foil over.
6. Pull the Handle down and press with a strong and long dwell (about 1-2 seconds.)
7. Remove the printout and gently peel off the foil.

NOTE:

- The printout needs to be from a laser printer or a photocopier that uses dry toner. Output from in-jet printers or copiers will not work with this process.

How to Imprint on Glasses using Crysteramics

Glass, ceramic or metal articles can be personalized by using the SLE product – Crysteramics. Crysteramics comes in many festive designs for all occasions. A name, a date or a short message is usually added to the design for personalization before applying to the article, such as a champagne glass.

1. Set the temperature to about 200 degrees.
2. Set the Type using the 2-Line or 3-Line Type Holder according to the instructions on typesetting. For best results use 12 or 14-point Type and P-series foil for printing.
3. Insert the Type Holder into the Machine.
4. Secure the include Crysteramics Guide on the Printing Table using the Gauge Bar.
5. Place a piece of the white test sample (included) in the Guide.
6. Make test imprints to check for positioning. Adjust the position of the Guide as necessary.
7. Place a piece of Crysteramics in the Guide
8. Imprint with a light short dwell.
9. Remove the Crysteramics and soak in a bowl of lukewarm water for one to two minutes or until the backing paper has absorbed enough water to allow it to separate easily from the clear film.
10. Pick up the Crysteramics and carefully position it on the surface of your article. Use your finger from one hand to hold down the transparent film and use your other hand to slide out the backing paper slowly from the other side.
11. Remove any excess water, air bubbles or wrinkles with a soft cloth or tissue paper. Wipe from the center outward. Be gentle so you do not shift the position or damage the film.
12. Let stand for a few hours or until the article is completely dry.
13. Preheat a conventional oven to 350 degree. Place the article into the oven and bake for about 10 minutes or until the Crysteramics film melts and becomes shiny. After baking, the film will become hardened.
14. Remove article from oven.

NOTE:

- Be sure that the article is completely dry before baking, otherwise steam or air bubbles underneath the Crysteramics will burst and ruin you hard work.

Supplies and Imprintables

Foils

Imprinting foils are available in a variety of colors and formulations. Your SLE Foil Color Chart gives you the wide selection of colors available. Some foil can be used adequately on a wide variety of material while others are specially formulated to print on designated substances. Foils for printing on paper stocks, however, are the most common. When in doubt, a test print will verify whether the intended foil is compatible with the material you are working with.

Most common formulation of foil:

- P-series – Metallic foil for general applications, satin ribbon and paper stocks.
- H-series – Metallic foil for paper napkins, rough surfaces and larger type.
- A-series – Pigment foil for a wide variety of applications.
- S-series – Metallic foil for fabrics, satin pillows and book covers.
- L-series – Specially formulated for leather articles
- K-series – Kopyfoil.

It is not possible to say for sure which foil is the best for the particular material you are printing on. If you have any doubts, our laboratory will be glad to help. Just send us a few samples of the item you are working on together with a self-addressed stamped envelope. Our technicians will test your samples and respond by return mail.

Type Sets, Spacers and Emblems

What is Available?

- A set of type usually contains the alphabets, punctuation marks and numerals.
- You can order full sets or half sets: Capitals or Lower Cases. Numerals and punctuation marks usually come with the capitals.
- Magnotypes are complete words or phrases cast in a single piece to make type setting less time consuming. Available in the more popular type styles and point sizes.
- Be sure to order Spacers that match the point size of your type set.
- Emblems are small graphic designs that compliment your type set. SLE has hundreds of emblems available for every festive occasion.
- Dies are available either from our available stock designs or custom made from you own black-and-white camera-ready artwork.
- Please consult your SLE catalog for available Emblem & Die designs, Type styles and point sizes.

Use Best Looking Size of Type for the Job

- You cannot expect the best looking effect when using the same size type for both short and long names.
- The size of the type should be in proportion to the length of the name and size of the merchandise. For example - short name in 18 Pt. Goudy Cursive may be well proportioned on billfolds, but a long name would crowd the space. It would look better in 12 or 14 Pt.
- On paper napkins use as large a type as possible - it looks better and is easier to imprint.
- A first name or monogram in Park Ave. type is very smart on small, informal notes, but would appear "lost" on a large sheet of stationery.
- On Christmas Cards, when imprinting longer names, select the more condensed type such as 12 Pt. Americana, 18 Pt. Murray Hill, etc. For short names use a larger size type or the name will look too small.
- Since you cannot control the size of the merchandise, or the length of the names, it is best to have two sizes of type in each of the more popular styles - one for long names and one for short names.
- On very short names use brass spacers between each letter.

Imprintables

SLE offers a wide selection of imprintables to help you create elegant gifts and favors. The selection is constantly updated to reflect what is popular in the market.

- Ribbons
- Favor Boxes
- Emboss-a-Plates
- Magnetic Address Books
- Crysteramics
- Matchbooks, Notepads, Toothpick Packages
- Favor Tags
- Coasters
- Napkin rings

Caring for Your SLE Hot Printer

Your new SLE Hot Printer is a sturdy, well-engineered, precision instrument, which, with careful handling and proper maintenance, will give you many years of productive, profitable service. From time to time, with constant use, certain parts of the SLE Hot Printer will need to be replaced. For example, the heating component is similar to a light bulb that is constantly being turned on and off; it burns out and eventually has to be replaced. Certain wear and tear parts such as the springs or cushion board will all need to be replaced periodically. You can easily do many of these repairs. However if you are uncomfortable performing this type of maintenance, send your machine in for a factory repair.

Routine Maintenance

Lubrication

Your SLE Hot Printer should be oiled at least once a week. Use any good quality machine oil for this purpose. Apply a few drops of oil to all four sides of the ram bar. Work the handle up and down a few times to let the oil penetrate. Wipe off excess oil.

Cleaning

Wipe the machine periodically with a clean cloth to prevent dust and oil build up. All accessories should be handled with care, and protectively stored away when not in use. Gently remove foil sludge with a little alcohol on a soft cloth. When not being used, cover the machine to protect it from dust.

Releasing Moisture in the AM-800 Compressor

The AM-800 Super Quiet Air Compressor is almost maintenance free. However a by-product of compressed air is moisture. The compressor is equipped with a moisture trap underneath the Filter Regulator. Turn clockwise the white valve at the bottom of the filter bowl and press to release any accumulated moisture. When finished, turn counter-clockwise to close the valve. This should be done daily. Hold a cloth underneath to absorb moisture.

Draining the Compressor

Once a week you need to drain the compressor on the AM-800. Turn off the compressor and verify that the gauge has returned to zero. Place a rag under the Petcock on the compressor tank and open the Petcock. When the tank is fully drained, close the Petcock.

How To Promote Sales

You cannot expect your customers to ask for personalization service unless they can see some samples and know that you can do the work. By publicizing your foil imprinting capabilities and enthusiastically promote the "magic" of foil imprinting, you will attract many new customers.

Arranging good-looking displays of imprinted samples is the best way to promote extra sales. You will experience many purchases made "on impulse" by customers who see your samples and realize the value of a personalized gift.

Whenever you make up an especially attractive order of personalized ribbon, book matches, paper napkins, etc., always remember to run extra pieces for your sample board.

List of Optional Accessories

	M-800A	M-800B	M-800E	M-800D
1-Line 18-point Type Holder	A8-LH1	B8-LH1	E8-LH1	D8-LH1
1-Line 24/36-point Type Holder	A8-LHM	B8-LHM	E8-LHM	D8-LHM
1-Line 72-point Type Holder	A8-WH72	B8-WH72	E8-WH72	D8-WH72
2-Line 18-point Type Holder	A8-LH2	B8-LH2	E8-LH2	D8-LH2
3-Line 18-point Type Holder		B8-LH3		
3-Line 12-point Type Holder	A8-LH312	B8-LH312	E8-LH312	D8-LH312
7-Line 18-point Type Holder	A8-LH7		A8-LH7	
1-Line Adapter Sleeve	A8-LA1	B8-LA2	A8-LA1	D8-LA1
Multi-line Adapter Sleeve	A8-LA2	B8-LA2	A8-LA2	D8-LA2
2-Line Adapter with Wafer Holder	A8-LA2WH	B8-LA2WH	A8-LA2WH	
Open Chase Type Holder	A8-OC1	B8-OC1	A8-OC1	D8-OC1
			E8-OC1	
2" Lead Rule Package	A8-OC2		A8-OC2	
Wafer Die Holder 108-point	E8-WH108	B8-WH108	E8-WH108	D8-WH108
Wafer Die Holder 160-point	E8-WH160		E8-WH160	
Wafer Holder for Open Chase	A8-WHOC		A8-WHOC	
Multi-purpose Gauge Bar	A8-GB	B8-GB	E8-GB	D8-GB
Billfold Clamp	A8-BLFD	B8-BLFD	E8-BLFD	E8-BLFD
Book Clamp	A8-BBL	B8-BBL	E8-BBL	E8-BBL
Pencil Attachment	A8-PG	B8-PG	E8-PG	D8-PG
Kopyfoil Attachment	A8-KFA	B8-KFA	E8-KFA	
Napkin Guide	A8-NG	B8-NG	A8-NG	A8-NG
Matchbook Guide	A8-MG	B8-MG	A8-MG	A8-MG
Ribbon Spindle	A8-RS	A8-RS	A8-RS	A8-RS
Ribbon Guide	A8-RG	B8-RG	E8-RG	D8-RG
Extended Printing Table	A8-EPT	B8-EPT	E8-EPT	E8-EPT
Wooden Type Box	C8-TBOX	C8-TBOX	C8-TBOX	C8-TBOX
Spacer Box	C8-SBOX	C8-SBOX	C8-SBOX	C8-SBOX
Holding Pad	C8-PAD	C8-PAD	C8-PAD	C8-PAD
Tweezers	C8-TWZ	C8-TWZ	C8-TWZ	C8-TWZ

SPECIFICATIONS

Model	M-800A	M-800B	M-800E	M-800D
Power Supply	110V AC 50 Hz			
Power Consumption	200 Watt			
Net Weight (Lb.)	19	16	20	20
Overall Dimension (in. W x D x H)	7.5 x 13.8 x 15.5	7.5 x 12.5 x 13	7.5 x 13.8 x 15.5	7.5 x 13.8 x 15.5
Printing Width (in.)	5.0	3.5	6.0	6.0
Printing Depth	2.3	1.5	2.3	1.5
Vertical Clearance	2.3 inch			
Color	White			

- Specifications are subject to change for improvement.
- 1 inch(in) = 25.4mm
- 1 pound(lb) = 0.454kg